

Meda Morph

Developed by Vitra in Switzerland
Design: Alberto Meda

Montageanleitung
Assembly instructions
Notice de montage
Instrucciones de montaje
Montagehandleiding
Istruzioni per il montaggio

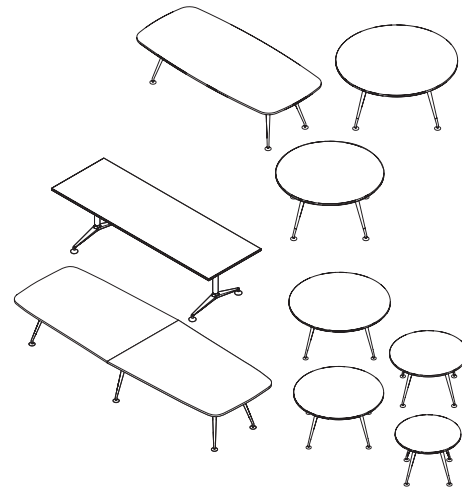

DE Inhalt

EN	Grundlegender Sicherheitshinweis	
FR	Lieferzustand	
ES	Vitra Service	
NL	Bestimmungsgemäßer Gebrauch	7—7
IT	Montage	20—48
	Pflegehinweis	50—53

Contents

Basic safety instructions	
Condition on delivery	
Vitra Service	
Intended use	7—7
Assembly	20—48
Care instructions	50—53

Sommaire

Consigne élémentaire de sécurité	
État à la livraison	
Service d'entretien Vitra	8—8
Utilisation conforme	20—48
Montage	50—53
Conseils d'entretien	

Índice

Normativa básica de seguridad	
Estado del producto	
Servicio de Vitra	
Uso conforme a lo previsto	8—8
Montaje	20—48
Consejos de conservación	50—53

Inhoud

Belangrijke veiligheidsrichtlijn	
Leveringstoestand	
Vitra Service	
Correct gebruik	9—9
Montage	20—48
Onderhoudsinstructie	50—53

Indice

Indicazioni di sicurezza generali	
Condizioni di fornitura	
Servizio di assistenza Vitra	
Utilizzo conforme	9—9
Montaggio	20—48
Indicazioni per la cura	50—53

Innhold

Grunnleggende sikkerhetsinformasjon	
Tilstand ved levering	
Vitra Service	
Forskriftsmessig bruk	10—10
Montering	20—48
Råd om vedlikehold	50—53

Съдържание

Основно указание за безопасност	
Състояние на доставка	
Vitra Service	
Употреба по предназначение	10—10
Монтаж	20—48
Указание за поддръжка	50—53

Indhold

Generelle sikkerhedsanvisninger	
Tilstand ved levering	
Vitra Service	
Anvendelse i henhold til formål	11—11
Montering	20—48
Plejeanvisninger	50—53

Sisukord

Tähtis ohutusmärkus	
Tarneolek	
Vitra teenindus	
Sihtotstarbeline kasutamine	11—11
Monteerimine	20—48
Hooldusmärkus	50—53

Sisältö

Perusturvallisuusohje	
Toimitustila	
Vitra-palvelu	
Määräystenmukainen käyttö	12—12
Asennus	20—48
Hoito-ohje	50—53

Περιεχόμενα

Βασική υπόδειξη ασφάλειας	
Κατάσταση παράδοσης	
Vitra Service	
Ενδεξιγμένη χρήση	12—12
Συναρμολόγηση	20—48
Υπόδειξη φροντίδας	50—53

LV Saturs

LT	Pamata drošības norādījums	
PL	Piegādes stāvoklis	
PT	Vitra serviss	
RO	Pareiza lietošana	13—13
SV	Montāža	20—48
	Norādījumi par kopšanu	50—53

Turinys

	Pagrindinė saugos nuoroda	
	Pristatomas komplektas	
	„Vitra“ techninės priežiūros skyrius	
	Naudojimas pagal paskirtį	13—13
	Montavimas	20—48
	Priežiūros nuoroda	50—53

Treść

	Zasadnicza wskazówka	
	bezpieczeństwa	
	Kompletność dostawy	
	Serwis firmy Vitra	
	Użycie zgodne z przeznaczeniem	14—14
	Montaż	20—48
	Wskazówka dot. pielęgnacji	50—53

Conteúdo

	Indicação básica de segurança	
	Estado do material fornecido	
	Assistência técnica da Vitra	
	Utilização correcta	14—14
	Montagem	20—48
	Instrução de uso e cuidado	50—53

Conținut

	Indicație de siguranță de bază	
	Starea de livrare	
	Serviciul pentru clienți Vitra	
	Utilizare conform destinației	15—15
	Montaj	20—48
	Indicație de îngrijire	50—53

Innehåll

	Grundläggande säkerhetsanvisningar	
	Leveransstatus	
	Vitra Service	
	Avsedd användning	15—15
	Montering	20—48
	Skötselansvisning	50—53

Obsah

Základné bezpečnostné upozornenie	
Stav pri dodaní	
Vitra Service	
Použitie s určeným účelom	16—16
Montáž	20—48
Pokyny pre údržbu a starostlivosť	50—53

Vsebina

Osnovni varnostni napotki	
Stanje ob dobavi	
Servis Vitra	
Namenska raba	16—16
Montaža	20—48
Napotki za nego	50—53

İçindekiler

Temel güvenlik uyarıları	
Teslimat durumu	
Vitra servisi	
Kurallara uygun kullanım	17—17
Montaj	20—48
Bakım uyarıları	50—53

Tartalom

Általános biztonsági megjegyzés	
Szállítási állapot	
Vitra szerviz	
Rendeltetésszerű használat	17—17
Összeszerelés	20—48
Ápolási tanácsok	50—53

Obsah

Základní bezpečnostní upozornění	
Stav při dodání	
Vitra Service	
Použití s určeným účelem	18—18
Montáž	20—48
Pokyny pro údržbu a péči	50—53

Efnisyfirlit

Mikilvægt almennt öryggisatriði	
Ástand við afhendingu	
Þjónustudeild Vitra	
Fyrirhuguð notkun	18—18
Úppsetning	20—48
Ábending varðandi umhirðu	50—53

HR Sadržaj

Osnovne sigurnosne napomene	
Stanje isporuke	
Servisna služba tvrtke Vitra	
Namjenska uporaba	19–19
Montaža	20–48
Napomene o održavanju	50–53

Grundlegender Sicherheitshinweis

⚠️ ACHTUNG! Lesen Sie diese Montageanleitung vor Gebrauch sorgfältig durch. Bewahren Sie diese zum späteren Nachlesen auf.

Lieferzustand

Überprüfen Sie Ihre Lieferung vor Montage auf Vollständigkeit.

Vitra Service

- Vitra Charles-Eames-Straße 2,
79576 Weil am Rhein
- <http://www.vitra.com>
- Vitra-Fachhandelspartner
- Vitra-Ländergesellschaften

Bestimmungsgemäßer Gebrauch

Nutzen Sie Ihren „Meda Morph“ unter Beachtung der allgemeinen Sorgfaltspflicht und bestimmungsgemäß nur als Tisch. Bei nicht bestimmungsgemäßem Gebrauch bestehen Verletzungsgefahr und Sachschäden.

Basic safety instructions

⚠️ ATTENTION! Read these assembly instructions carefully before use and retain them for later reference.

Condition on delivery

Check that your delivery is complete before assembly.

Vitra Service

- Vitra Charles-Eames-Straße 2,
79576 Weil am Rhein
- Web: <http://www.vitra.com>
- Vitra retail partner
- Vitra international subsidiaries

Intended use

Only use your “Meda Morph” for its intended purpose and exercise all due caution when using it. Using this product for purposes other than those intended may lead to injury or damage to property.

FR **Consigne élémentaire de sécurité**

ES

⚠ATTENTION! Lisez minutieusement l'intégralité de cette notice de montage avant toute utilisation. Conservez-la précieusement pour consultation ultérieure.

État à la livraison

Avant le montage, vérifiez que la livraison est complète.

Service d'entretien Vitra

- Vitra Charles-Eames-Straße 2, 79576 Weil am Rhein
- Web: <http://www.vitra.com>
- revendeurs Vitra
- filiales nationales Vitra

Utilisation conforme

N'utilisez votre « Meda Morph » qu'en tant que table et respectez les règles élémentaires de sécurité. Toute utilisation non conforme entraîne un risque de dommages corporels ou matériels.

Normativa básica de seguridad

⚠¡ATENCIÓN! Lea detenidamente estas instrucciones de montaje antes de usar el producto y guárdelas para posibles consultas en el futuro.

Estado del producto

Antes de proceder al montaje, compruebe que la entrega incluye todas las piezas necesarias.

Servicio de Vitra

- Vitra Charles-Eames-Straße 2, 79576 Weil am Rhein, Alemania
- Página web: <http://www.vitra.com>
- Distribuidores de Vitra
- Sociedades nacionales de Vitra

Uso conforme a lo previsto

Haga uso de su «Meda Morph» atendiendo a las normas generales de conservación y únicamente como mesa conforme al uso para el que ha sido concebida. En caso de que no se lleve a cabo un uso acorde con las disposiciones se pueden producir daños personales y materiales.

Belangrijke veiligheidsrichtlijn

⚠ OPGELET! Lees de gebruiksaanwijzing aandachtig voor gebruik. Berg ze zorgvuldig op, zodat u ze later nog kunt raadplegen.

Leveringstoestand

Controleer uw levering op volledigheid voordat u aan de montage begint.

Vitra Service

- Vitra Charles-Eames-Straße 2, D-79576 Weil am Rhein
- Website: <http://www.vitra.com>
- Vitra-dealers
- Vitra-landenfirma's

Correct gebruik

Gebruik de Meda Morph op verantwoordelijke en correcte wijze en alleen als tafel. Niet-correct gebruik kan leiden tot lichamelijk letsel of materiële schade.

Indicazioni di sicurezza generali

⚠ ATTENZIONE! Leggere attentamente le istruzioni per il montaggio prima di utilizzare il prodotto. Conservarle accuratamente per riferimento futuro.

Condizioni di fornitura

Verificare accuratamente la completezza degli elementi della fornitura.

Servizio di assistenza Vitra

- Vitra Charles-Eames-Straße 2, 79576 Weil am Rhein
- Web: <http://www.vitra.com>
- Rivenditori Vitra
- Sedi nazionali Vitra

Utilizzo conforme

Utilizzare il "Meda Morph" in osservanza delle norme generali di sicurezza e, in conformità alla sua destinazione d'uso, esclusivamente come tavolo. L'utilizzo improprio comporta il rischio di lesioni e danni materiali.

NO Grunnleggende sikkerhetsinformasjon

BG  **OBS!** Les nøye gjennom monteringsveiledningen før bruk.

Ta vare på den slik at du kan slå opp i den senere.

Tilstand ved levering

Kontroller at leveransen er komplett før du starter monteringen.

Vitra Service

- Vitra Charles-Eames-Straße 2, 79576 Weil am Rhein , Tyskland
- Web: <http://www.vitra.com>
- Vitra-fagforhandlerpartner
- Vitra-landsselskap

Forskriftsmessig bruk

Utvis generell aktsomhet og bruk ditt „Meda Morph“ kun forskriftsmessig som bord. Ikke forskriftsmessig bruk kan medføre fare for personskader og materielle skader.

Основно указание за безопасност

 **ВНИМАНИЕ!** Внимателно прочетете инструкцията за монтаж.

Запазете я за по-късни справки..

Състояние на доставка

Преди монтаж проверете дали доставката е в пълен комплект.

Vitra Service

- Vitra Charles-Eames-Straße 2, 79576 Weil am Rhein
- Web: <http://www.vitra.com>
- Vitra - търговски партньори
- Vitra - дъщерни дружества

Употреба по предназначение

Използвайте вашата „Meda Morph“ като съблюдавате общото задължение за добросъвестност и по предназначение само като маса. При употреба, различна от употребата по предназначение, съществува опасност от нараняване или материални щети.

Generelle sikkerhedsanvisninger

 **OBS!** Læs denne montagevejledning omhyggeligt igennem inden ibrugtagning. Opbevar den til eventuel senere brug.

Tilstand ved levering

Kontroller inden monteringen, at leveringen er komplet.

Vitra Service

- Vitra Charles-Eames-Straße 2, D-79576 Weil am Rhein, Tyskland
- Web: <http://www.vitra.com>
- Autoriserede Vitra-forhandlere
- Vitra-datterselskaber

Anvendelse i henhold til formål

„Meda Morph“ må kun anvendes i henhold til sit formål som bord og under overholdelse af fornøden generel omhu og agtpågivenhed. Ved ikke-formålsbestemt anvendelse er der fare for tilskadekomst og materiel skade.

Tähtis ohutusmärkus

 **TÄHELEPANUG!** Lugege paigaldusjuhend enne seadme kasutamist hoolikalt läbi. Hoidke kasutusjuhend alles, et saaksite seda ka hiljem lugeda.

Tarneolek

Kontrollige enne monteerimist tarnekomplekti terviklikkust.

Vitra teenindus

- Vitra Charles-Eames-Straße 2, 79576 Weil am Rhein
- Veebiaadress: <http://www.vitra.com>
- Vitra müügiesindajad
- Vitra regionaalsed äriühingud

Sihtotstarbeline kasutamine

Kasutage Meda Morph'it hoolikalt ja selleks ettenähtud otstarbel ainult lauana. Mittesihipärase kasutuse korral esineb vigastusohu ja võib tekkida materiaalne kahju.

FI Perusturvallisuusohje



⚠️ HUOMIO! Perehdy käyttöohjeeseen huolellisesti ennen käyttöä. Säilytä se myöhempää käyttöä varten.

Toimitustila

Tarkista ennen asennusta, että kaikki toimitukseen kuuluvat osat on toimitettu.

Vitra-palvelu

- Vitra Charles-Eames-Straße 2, D- 79576 Weil am Rhein
- Internet: <http://www.vitra.com>
- Vitra-myyntikumppanit
- Vitra-tytäryhtiöt

Määräystenmukainen käyttö

Noudata riittävää huolellisuutta käyttäessäsi Meda Morph -pöytää, ja käytä sitä sen käyttötarkoituksen mukaisesti vain pöytänä.

Määräystenvastainen käyttö voi johtaa loukkaantumisiin tai aineellisiin vahinkoihin.

Βασική υπόδειξη ασφάλειας



ΠΡΟΣΟΧΗ! Πριν από τη χρήση διαβάστε προσεκτικά αυτές τις οδηγίες συναρμολόγησης. Φυλάξτε τις για να τις συμβουλευτείτε στο μέλλον.

Κατάσταση παράδοσης

Ελέγξτε την προμήθεια πριν από τη συναρμολόγηση ως προς την πληρότητά της.

Vitra Service

- Vitra Charles-Eames-Straße 2, 79576 Weil am Rhein
- Διαδίκτυο: <http://www.vitra.com>
- Εμπορικές αντιπροσωπείες Vitra
- Κατά χώρες θυγατρικές εταιρείες της Vitra

Ενδεδειγμένη χρήση

Χρησιμοποιείτε το «Meda Morph» σας τηρώντας τη γενική υποχρέωση επιμέλειας και μόνο για τον προβλεπόμενο σκοπό χρήσης του ως τραπέζιού. Σε περίπτωση μη ενδεδειγμένης χρήσης υπάρχει κίνδυνος τραυματισμού και υλικών ζημιών.

Pamata drošības norādījums

⚠️ UZMANĪBU! Pirms lietošanas rūpīgi izlasiet šo montāžas instrukciju. Saglabājiet to, lai vēlāk varētu pārlasīt.

Piegādes stāvoklis

Pirms montāžas pārliecinieties, ka piegādāts pilns komplekts.

Vitra Service

- Vitra Charles-Eames-Straße 2,
79576 Weil am Rhein
- Mājas lapa: <http://www.vitra.com>
- Vitra tirdzniecības pārstāvji
- Vitra pārstāvji citās zemēs

Pareiza lietošana

Izmantojiet savu „Meda Morph” ar atbilstošu rūpību un tikai kā galdu. Nepareizi lietojot, var rasties ievainojumu gūšanas risks un izstrādājuma bojājumi.

Pagrindinē saugos nuoroda

⚠️ DĒMESIO! Prieš pradēdami naudoti atidžiai perskaitykite šią montavimo instrukciją. Išsaugokite instrukciją, kad galėtumėte paskaityti vėliau.

Pristatomas komplektas

Prieš pradēdami montuoti, patikrinkite, ar pristatytame komplekte yra visos dalys.

„Vitra” techninės priežiūros skyrius

- Vitra Charles-Eames-Straße 2,
79576 Weil am Rhein
- Interneto svetainė: <http://www.vitra.com>
- „Vitra” specializuotos prekybos partneriai
- „Vitra” pavaldžiosios bendrovės

Naudojimas pagal paskirtį

Naudokite savo „Meda Morph” laikydamiesi bendrų naudojimo reikalavimų ir tik pagal paskirtį, t. y. kaip stalą. Naudojant ne pagal paskirtį kyla pavojus susižaloti arba padaryti materialinės žalos.

PL Podstawowa wskazówka bezpieczeństwa

PT

⚠ UWAGA! Przed użyciem należy starannie przeczytać niniejszą instrukcję montażu. Przechowywać instrukcję do późniejszego czytania.

Kompletność dostawy

Przed montażem należy sprawdzić dostawę pod względem kompletności.

Serwis firmy Vitra

- Vitra Charles-Eames-Straße 2, 79576 Weil am Rhein
- Web: <http://www.vitra.com>
- Partnerzy firmy Vitra w handlu specjalistycznym
- Spółki krajowe firmy Vitra

Użycie zgodne z przeznaczeniem

„Meda Morph” należy używać zgodnie z przeznaczeniem tylko jako stołu, przestrzegając ogólnego obowiązku staranności. Użycie niezgodne z przeznaczeniem może skutkować obrażeniami lub uszkodzami rzeczowymi.

Indicação básica de segurança

⚠ ATENÇÃO! Antes da utilização leia cuidadosamente as instruções de montagem. Guarde-as para utilização posterior.

Estado do material fornecido

Antes da montagem, monitorize o material fornecido quanto à sua integridade.

Assistência técnica da Vitra

- Vitra Charles-Eames-Straße 2, 79576 Weil am Rhein
- Web: <http://www.vitra.com>
- Distribuidor Vitra
- Empresas representantes Vitra

Utilização correcta

Utilize a sua „Meda Morph” respeitando o dever geral de diligência e de modo apropriado ao fim a que se destina, como mesa. Existe perigo de ferimentos e danos materiais em caso de utilização indevida.

Indicație de siguranță de bază

⚠️ ATTENTION! Anterior utilizării citiți cu atenție prezentele instrucțiuni de montaj. Păstrați-le pentru consultarea ulterioară.

Starea de livrare

Anterior montării verificați pachetul de livrare pentru a vedea dacă este complet.

Serviciul pentru clienți Vitra

- Vitra Charles-Eames-Straße 2,
79576 Weil am Rhein
- Web: <http://www.vitra.com>
- Parteneri comerciali Vitra
- Reprezentanțe Vitra

Utilizare conform destinației

Utilizați „Meda Morph” respectând obligația generală de diligență și numai în conformitate cu destinația de utilizare ca masă. În caz de utilizare neconformă cu destinația, există pericol de accidentare sau de producere a daunelor materiale.

Grundläggande säkerhetsanvisningar

⚠️ OBSERVERA! Läs denna monteringsanvisning noggrant före användning. Spara den för läsning vid senare tillfälle.

Leveransstatus

Kontrollera att leveransen är fullständig före montering.

Vitra Service

- Vitra Charles-Eames-Straße 2,
79576 Weil am Rhein
- Web: <http://www.vitra.com>
- Vitra-återförsäljare
- Vitra-företag i respektive land

Avsedd användning

„Meda Morph” bör användas med ett mått av försiktighet och uteslutande som bord. Om man inte använder bordet på avsett vis finns det risk för person- och materialskador.

SK Základné bezpečnostné upozornenie

SL ⚠ POZOR! Pred použitím si dôkladne prečítajte tento návod na montáž. Uschovajte si ho pre prípad neskoršieho použitia.

Stav pri dodaní

Skontrolujte pred montážou svoju dodávku, či je kompletná.

Vitra Service

- Vitra Charles-Eames-Straße 2, 79576 Weil am Rhein
- Web: <http://www.vitra.com>
- Odborní obchodní partneri Vitra
- Národné spoločnosti Vitra

Utilizare conform destinației

Používajte váš „Meda Morph“ s dodržiavaním celkovej povinnej starostlivosti a podľa určenia len ako stôl. Pri použití v rozpore s určením hrozí nebezpečenstvo poranenia a vecných škôd.

Osnovni varnostni napotki

⚠ POZOR! Pred uporabo temeljito preberite ta navodila za montažo. Shranite jih za nadaljnjo uporabo.

Stanje ob dobavi

Pred montažo preverite, ali so dostavljeni vsi deli in ali so nepoškodovani.

Vitra Service

- Vitra Charles-Eames-Straße 2, 79576 Weil am Rhein
- Web: <http://www.vitra.com>
- Prodajni partnerji družbe Vitra
- Nacionalna zastopstva družbe Vitra

Namenska raba

Vašo mizo „Meda Morph“ uporabljajte z upoštevanjem splošne skrbnosti in v skladu z namenom samo kot mizo. Neustrezna uporaba lahko povzroči nevarnost telesnih poškodb in gmotne škode.

Temel güvenlik uyarıları

⚠ DİKKAT! Ürünü kullanmadan önce bu montaj kılavuzunu dikkatlice okuyunuz. Daha sonra tekrar okumak için kılavuzu saklayınız.

Teslimat durumu

Montajdan önce teslimatın eksiksiz olup olmadığını kontrol ediniz.

Vitra servis

- Vitra Charles-Eames-Straße 2,
79576 Weil am Rhein
- Web: <http://www.vitra.com>
- Vitra yetkili satıcıları
- Vitra ülke şirketleri

Kurallara uygun kullanım

Meda Morph'nizi genel itina sorumluluğuna dikkat ederek ve amacına uygun olarak yalnız masa olarak kullanın. Usulüne aykırı kullanım durumunda yaralanma ve maddi hasar tehlikesi bulunmaktadır.

Általános biztonsági megjegyzés

⚠ FIGYELEM! Használat előtt figyelmesen olvassa el a Szerelési útmutatót.
Őrizze meg, hogy a később felmerülő kérdéseknek utána tudjon nézni.

Szállítási állapot

Összeszerelés előtt ellenőrizze a szállítmány hiánytalanságát.

Vitra szerviz

- Vitra Charles-Eames-Straße 2,
79576 Weil am Rhein
- Weboldal: <http://www.vitra.com>
- Vitra szakkereskedő partner
- Vitra leányvállalat

Rendeltetészerű használat

A „Meda Morph” asztalt mindig az általános gondossági kötelezettség figyelembe vételével, a rendeltetésének megfelelően, csak asztalként használja. A nem rendeltetészerű használat személyi sérüléshez vagy anyagi károkhoz vezethet.

CS Základní bezpečnostní upozornění

IS **⚠ POZOR!** Před použitím si pozorně přečtěte tento návod k montáži. Uschovejte jej pro budoucí použití.

Stav při dodání

Zkontrolujte před montáží svou dodávku, zda je kompletní.

Vitra Service

- Vitra Charles-Eames-Straße 2, 79576 Weil am Rhein
- Web: <http://www.vitra.com>
- Odborní obchodní partneři Vitra
- Národní společnosti Vitra

Použití s určeným účelem

Používejte „Meda Morph“ s povinnou pečlivostí a pouze k určenému účelu jako stůl. Při použití v rozporu s určeným účelem hrozí nebezpečí zranění a škody na majetku.

Mikilvægt almennt öryggisatriði

⚠ ATHUGIÐ! Lesið þessar uppsetningarleiðbeiningar vandlega fyrir notkun. Geymið leiðbeiningarnar til síðari nota.

Ástand við afhendingu

Áður en hafist er handa við samsetningu skal ganga úr skugga um að engi hluti vanti.

Þjónustudeild Vitra

- Vitra Charles-Eames-Straße 2, 79576 Weil am Rhein
- Web: <http://www.vitra.com>
- Söluaðilar Vitra
- Umboðsaðilar Vitra

Fyrirhuguð notkun

Gæta skal að almennum öryggisatriðum við notkun „Meda Morph“ og ekki nota það í öðrum tilgangi en sem borð. Hætta er á slysum og tjóni ef notkun er ekki með fyrirhuguðum hætti.

Osnovne sigurnosne napomene

⚠ POZOR! Prije uporabe pažljivo pročitajte ove upute za montažu. Spremite upute kako biste ih kasnije mogli prelistati.

Stanje isporuke

Prije montaže provjerite potpunost isporuke.

Servisna služba tvrtke Vitra

- Vitra Charles-Eames-Straße 2,
79576 Weil am Rhein
- Internetska stranica: <http://www.vitra.com>
- Partner specijalizirane trgovine tvrtke Vitra
- Regionalne podružnice tvrtke Vitra

Namjenska uporaba

„Meda Morph“ upotrebljavajte na pravilan način i to isključivo kao stol, uzimajući u obzir opću odgovornost pažljivog postupanja. U slučaju nenamjenske uporabe postoji opasnost od ozljeda i materijalne štete.



21—21

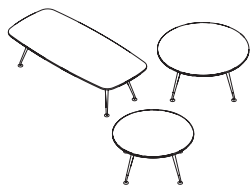

22—31

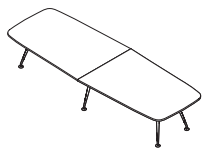

32—43



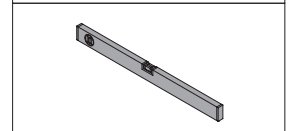
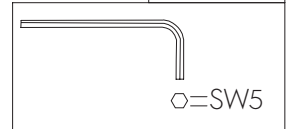
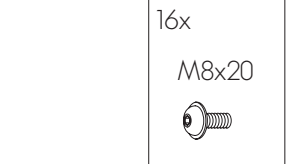
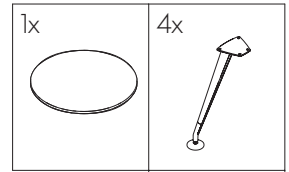
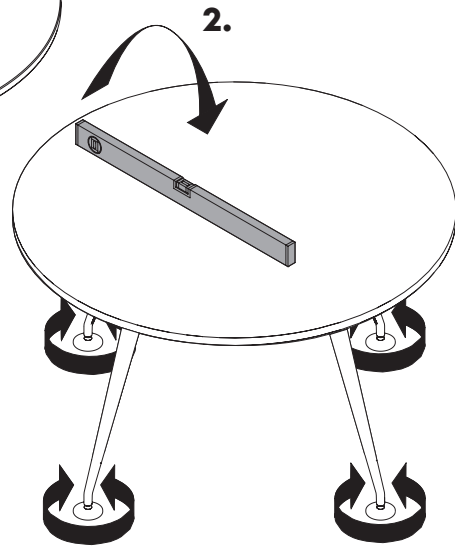
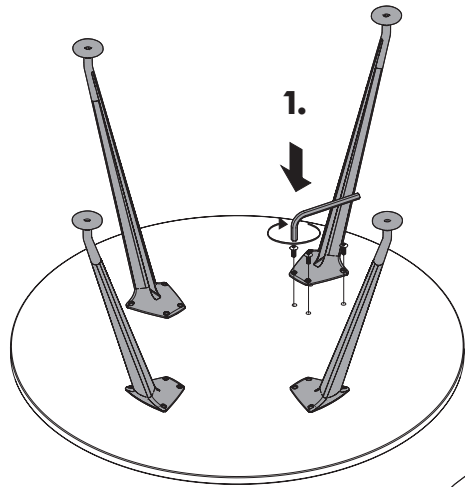

44—48

A

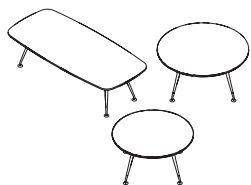

A

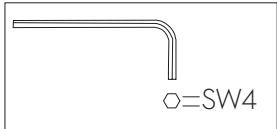
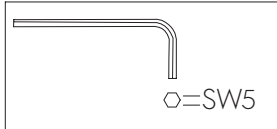
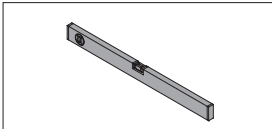
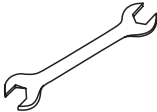

1x ?	6x	2x	2x	 <p>○=SW4</p>  <p>○=SW5</p> 	 
12x	4x	3x	2(4x)		
4-8x M8x16	4x				

B

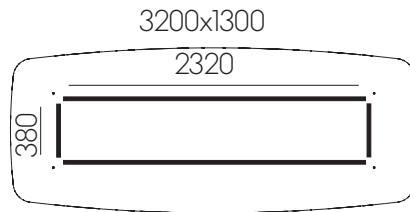
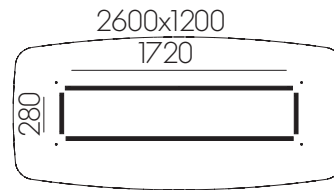
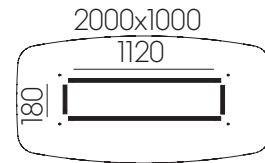
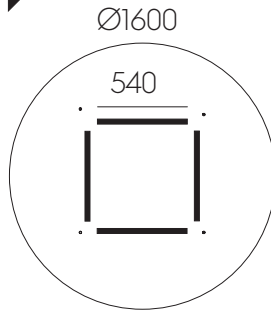
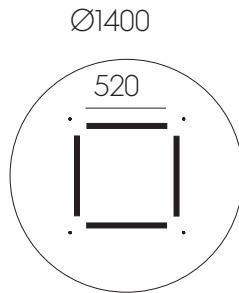
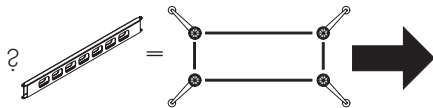
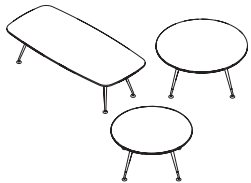

C

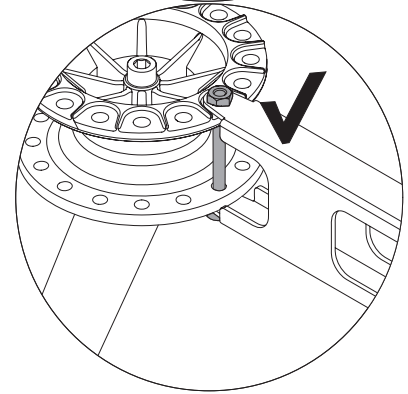
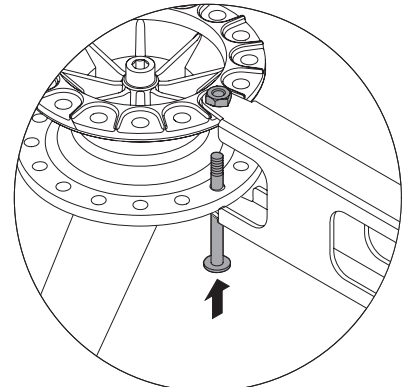
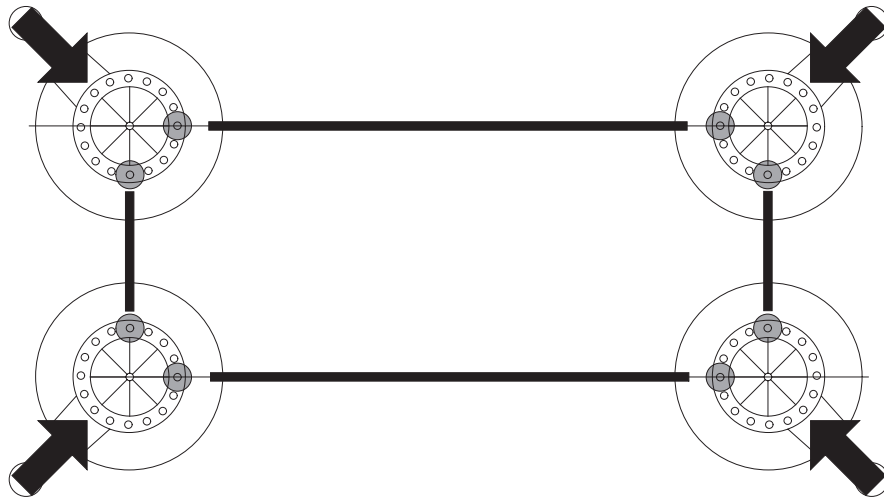
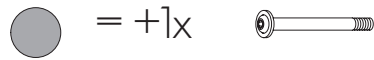
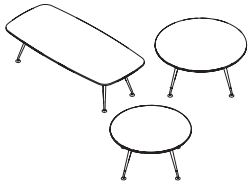

D

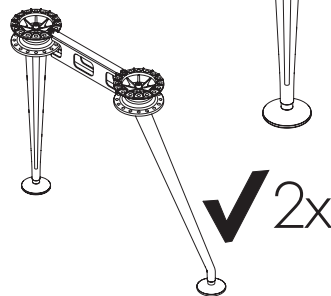
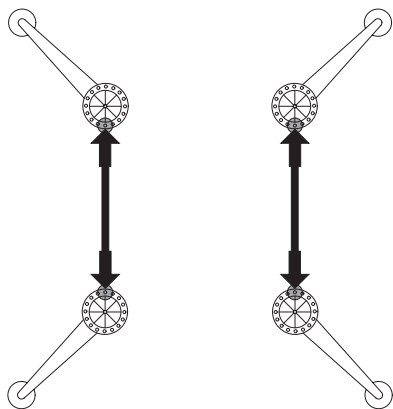
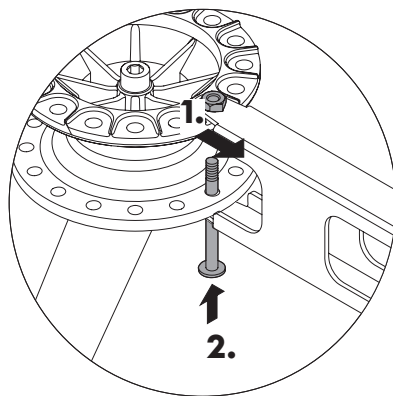
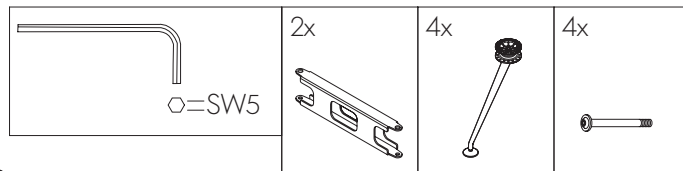
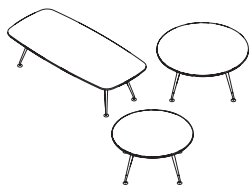

- DE** Leicht anziehen.
- EN** Tighten slightly.
- FR** Serrer légèrement.
- ES** Apriete ligeramente.
- NL** Niet te sterk aandraaien.
- IT** Avvitare leggermente.

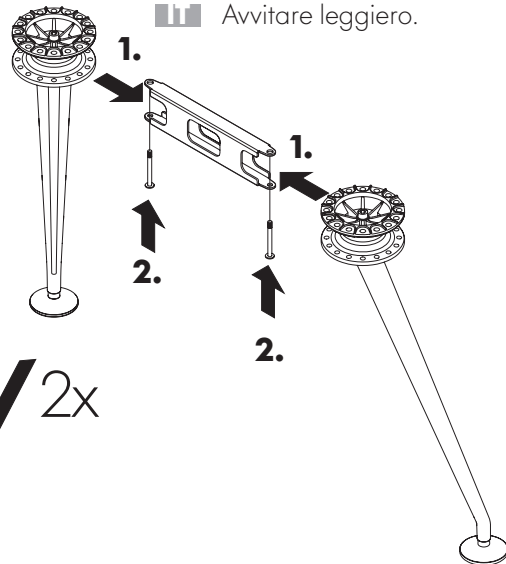

E

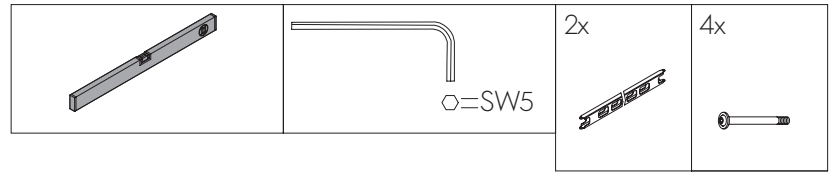
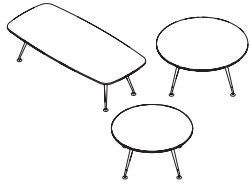

- DE** Leicht anziehen.
- EN** Tighten slightly.
- FR** Serrer légèrement.
- ES** Apriete ligeramente.
- NL** Niet te sterk aandraaien.
- IT** Avvitare leggermente.

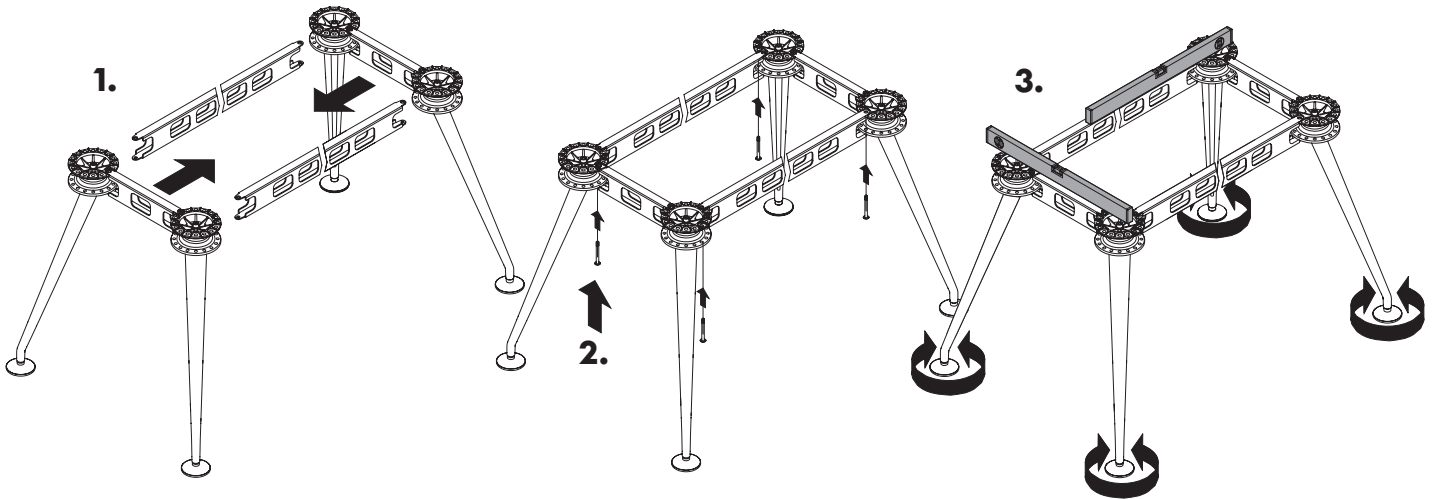

F

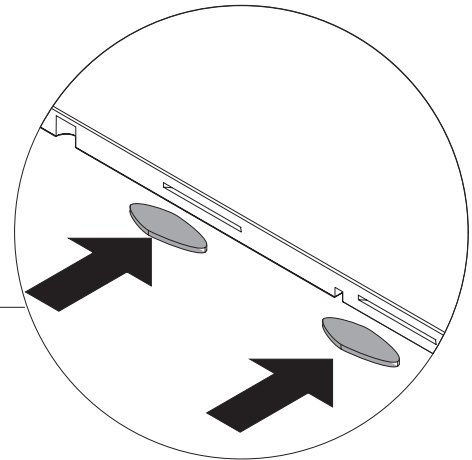
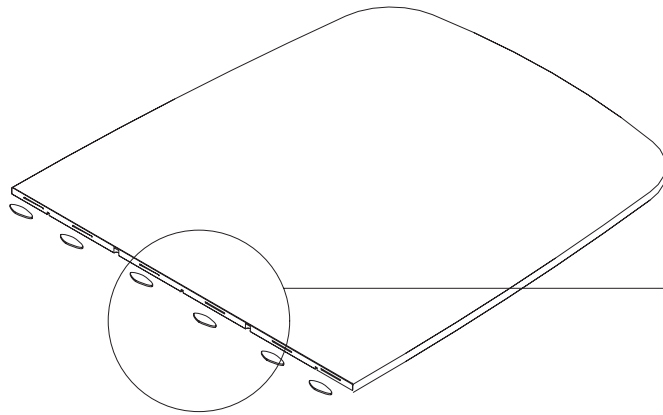
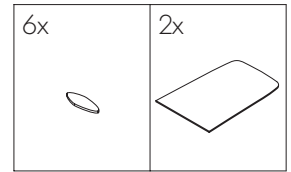
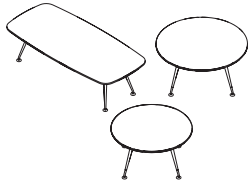

G

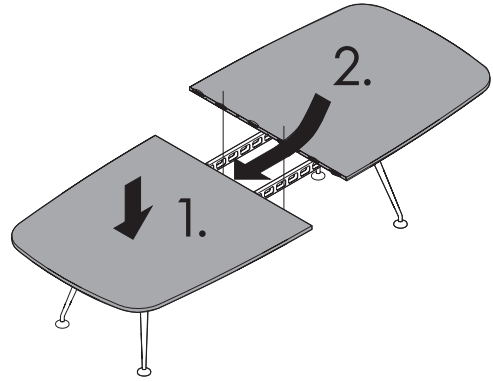
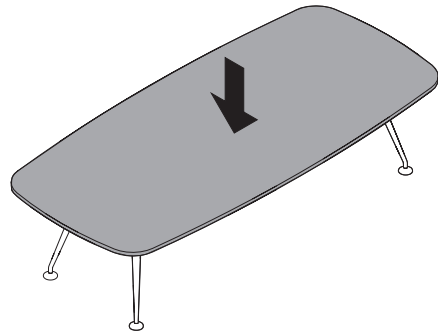
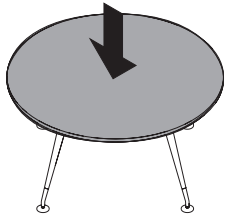
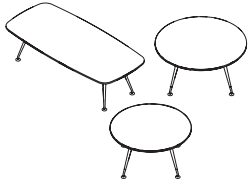
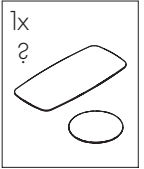

H

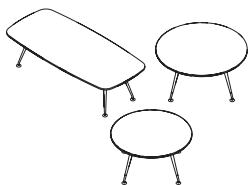

- DE** Leicht anziehen.
- EN** Tighten slightly.
- FR** Serrer légèrement.
- ES** Apriete ligeramente.
- NL** Niet te sterk aandraaien.
- IT** Avvitare leggero.

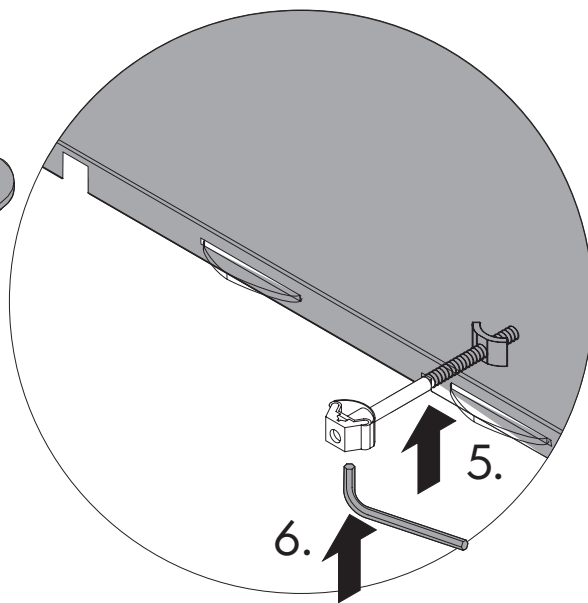
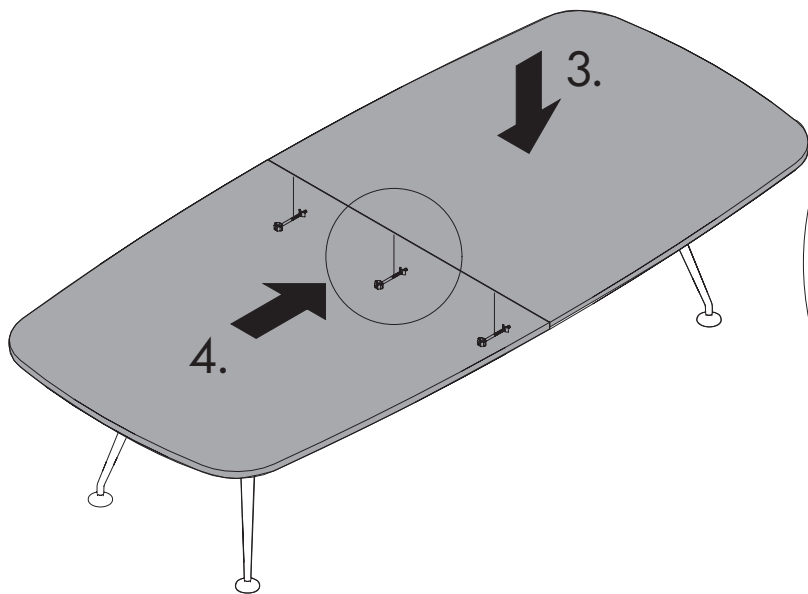
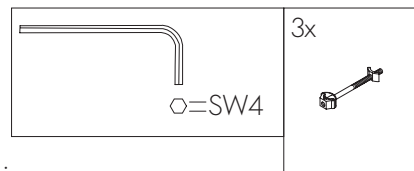

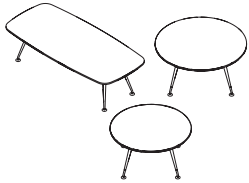

● = M8x16 

○ =  



Ø1400

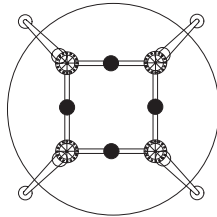

Ø1600

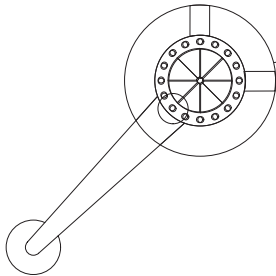
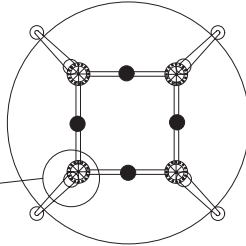

2000x1000

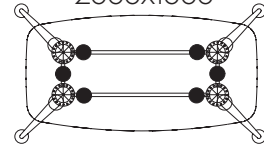

2600x1200

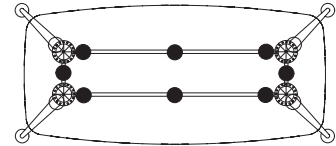

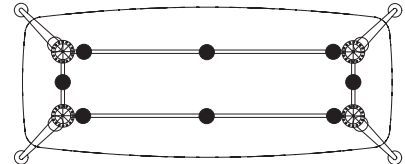

3200x1300

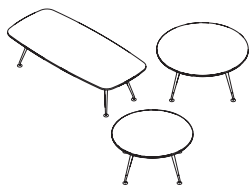

J





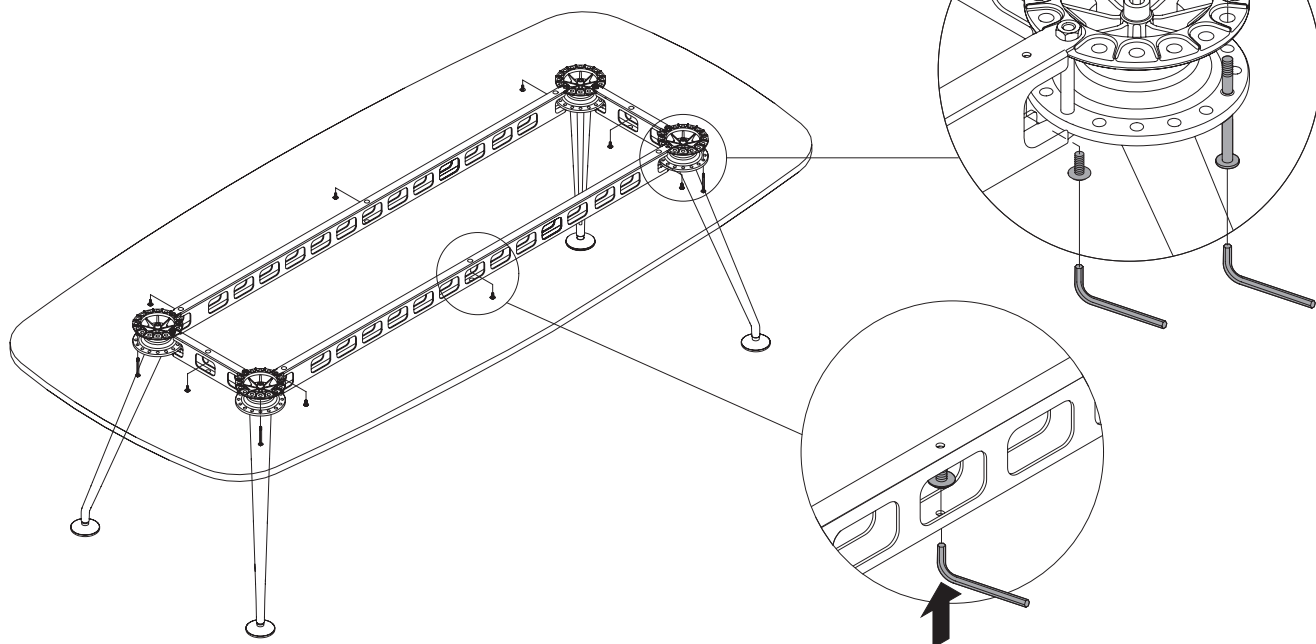

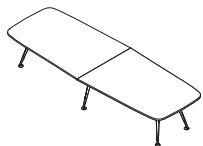

- DE** Alles fest anziehen.
EN All thighten fully.
FR Tout serrer fortement.
ES Todo apriete fijo.
NL Alles vast aandraaien.
IT Tutto avvitare fermo.

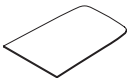

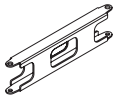
 ○=SW5	4-8x	4x	4x
	M8x16		

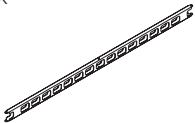



A

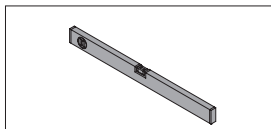

2x 	6x 	3x 
18x 	3x 	4x 
10x M8x16 	4x 	6x 

 ○=SW4
 ○=SW5





B

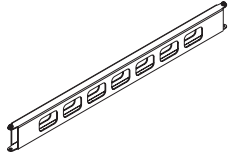
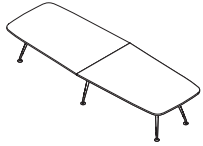

=

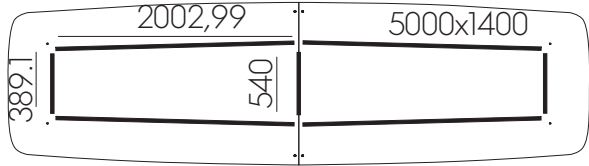
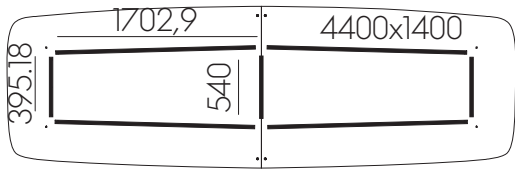
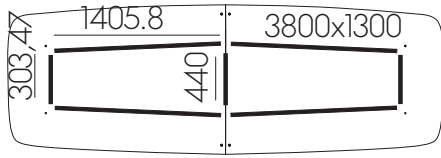
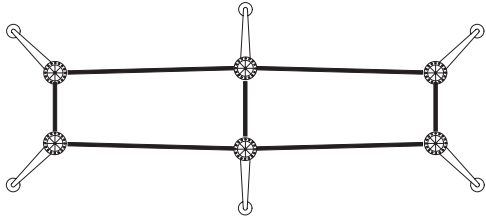

C

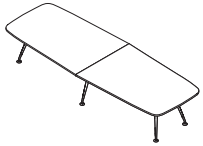

● = +1x

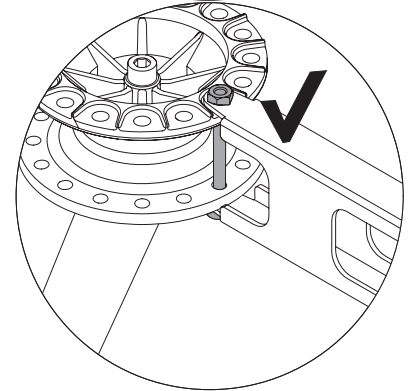
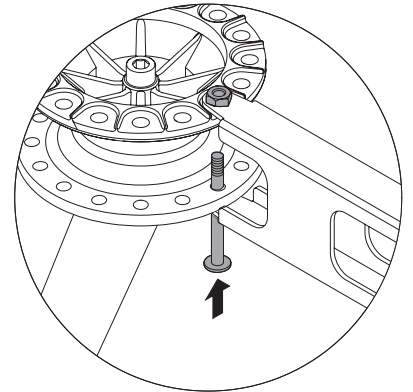
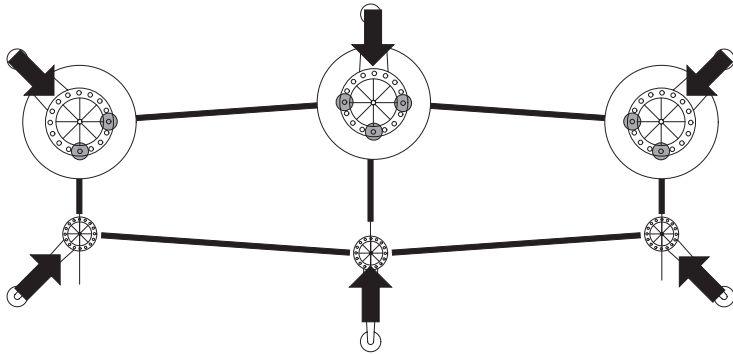

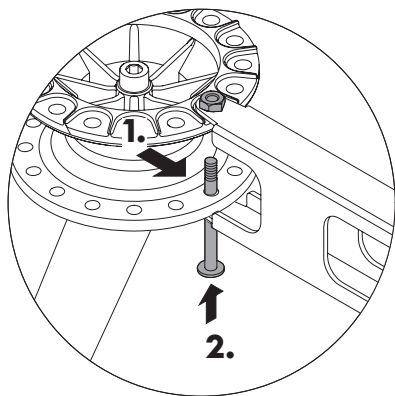
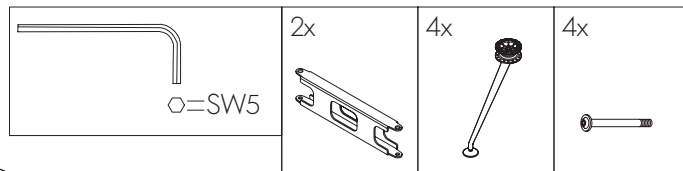
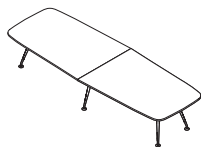
D

- DE** Leicht anziehen.
- EN** Tighten slightly.
- FR** Serrer légèrement.
- ES** Apriete ligeramente.
- NL** Niet te sterk aandraaien.
- IT** Avvitare leggiero.

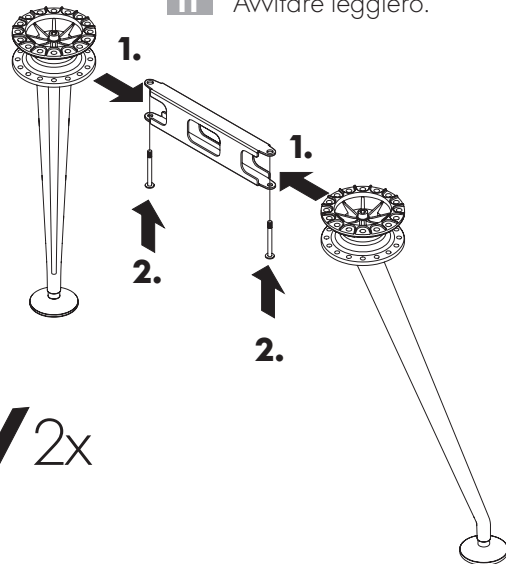
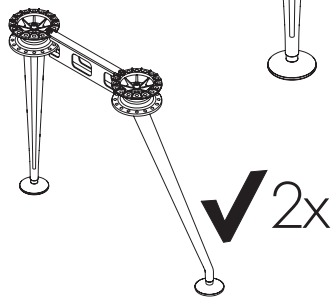
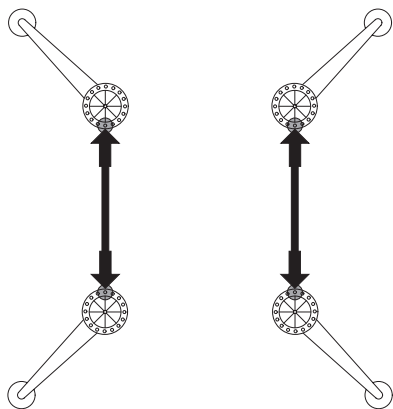

E

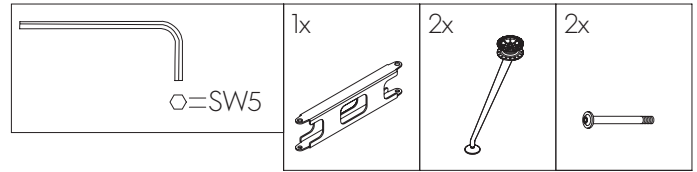
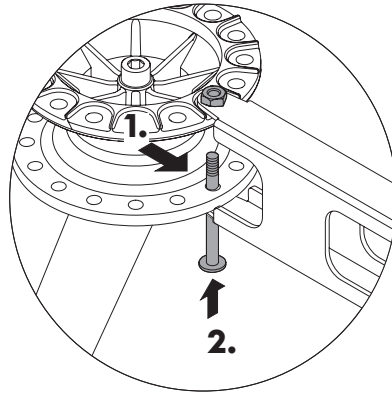
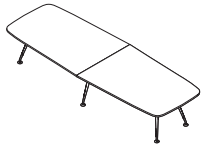

- DE** Leicht anziehen.
- EN** Tighten slightly.
- FR** Serrer légèrement.
- ES** Apriete ligeramente.
- NL** Niet te sterk aandraaien.
- IT** Avvitare leggero.

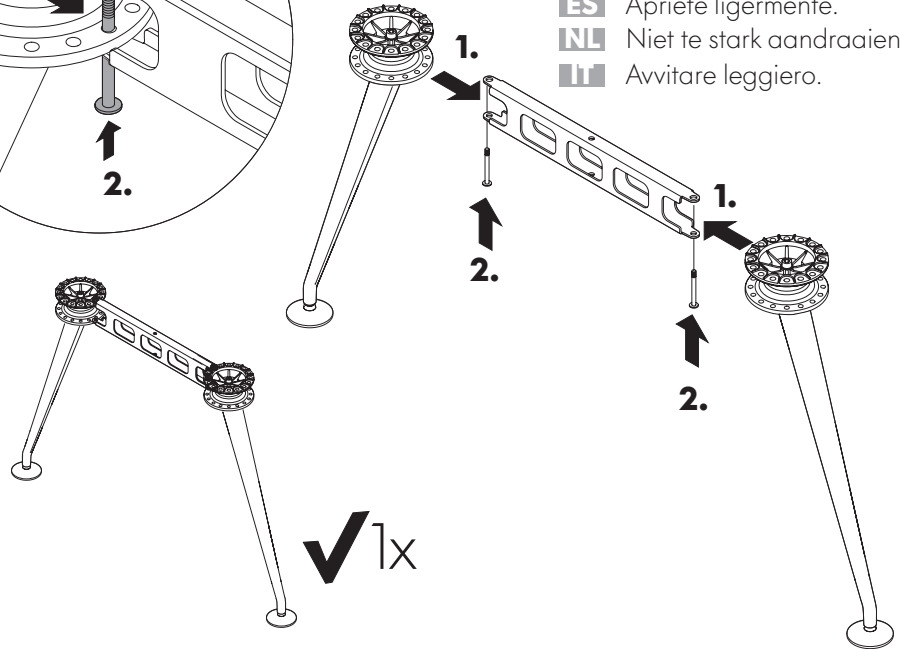

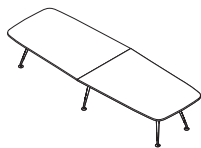
F

- DE** Leicht anziehen.
- EN** Tighten slightly.
- FR** Serrer légèrement.
- ES** Apriete ligeramente.
- NL** Niet te sterk aandraaien.
- IT** Avvitare leggiero.

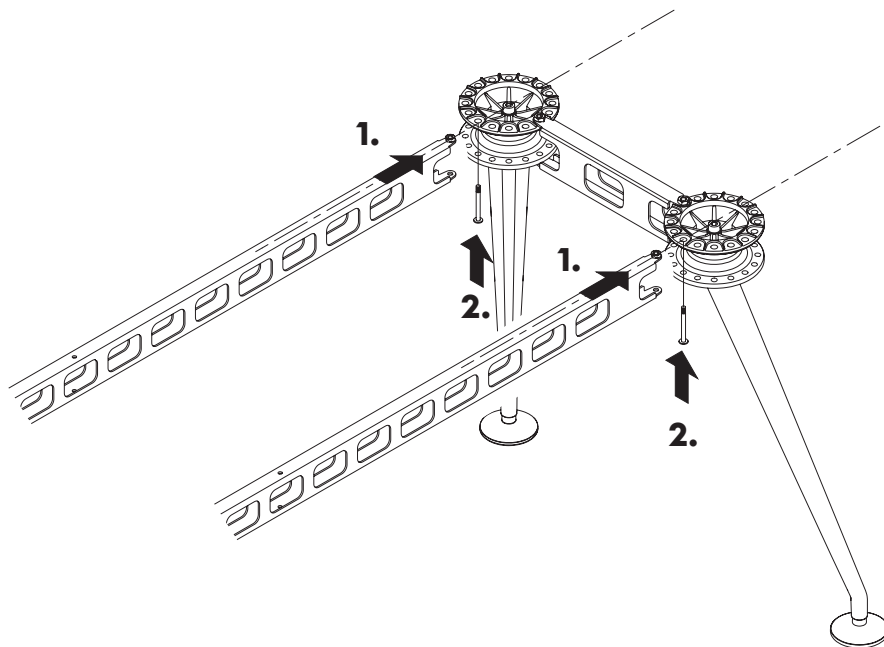
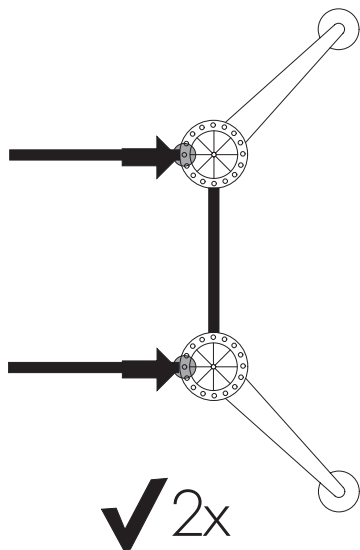
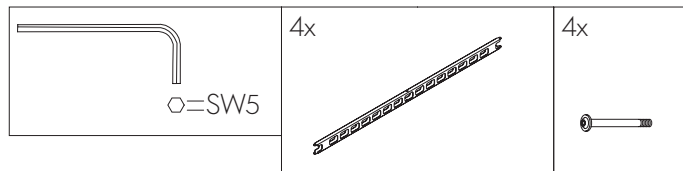

G

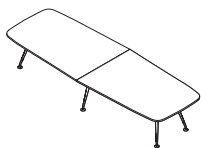

- DE** Leicht anziehen.
- EN** Tighten slightly.
- FR** Serrer légèrement.
- ES** Apriete ligeramente.
- NL** Niet te sterk aandraaien.
- IT** Avvitare leggero.

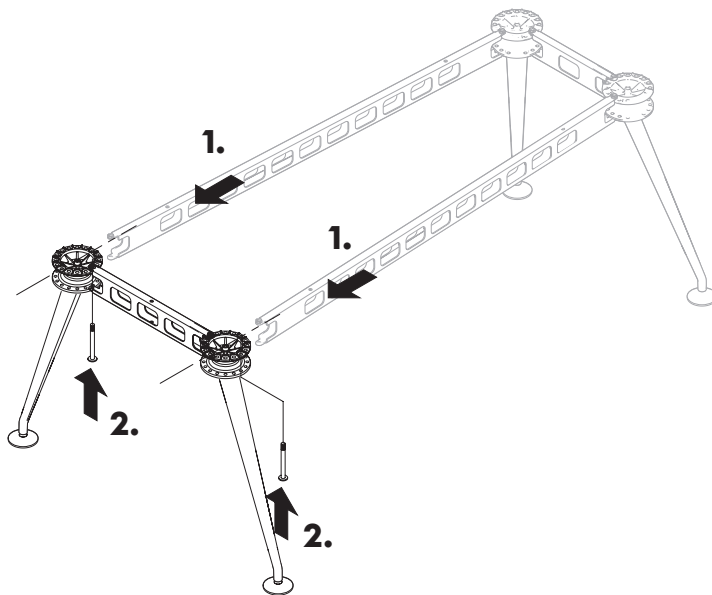
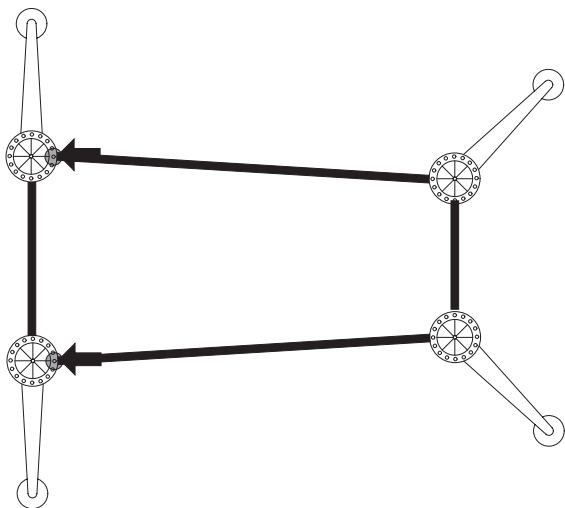
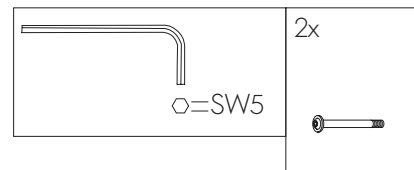

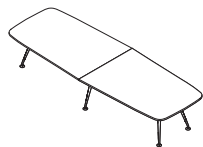

H

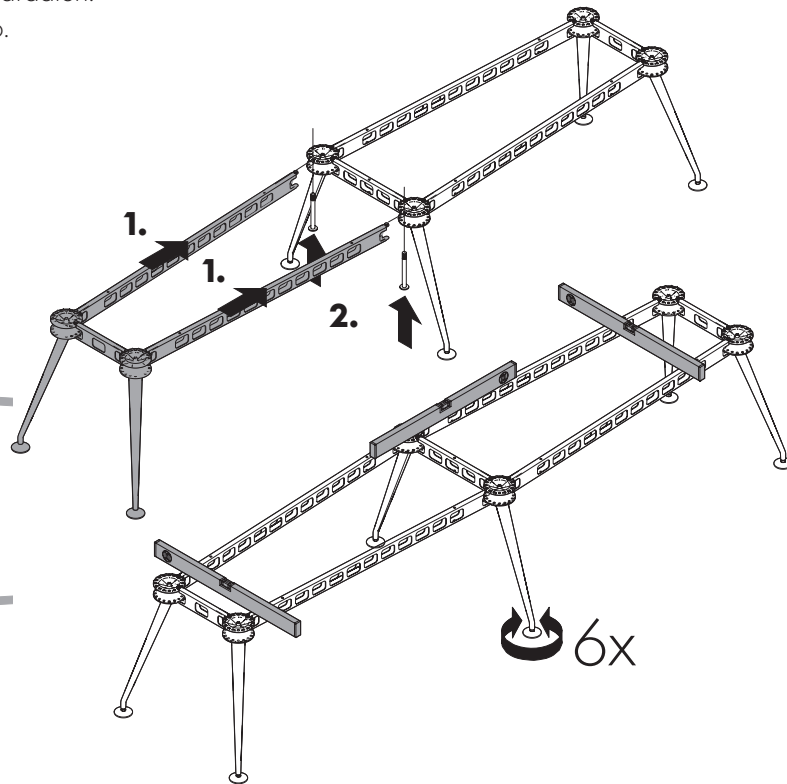
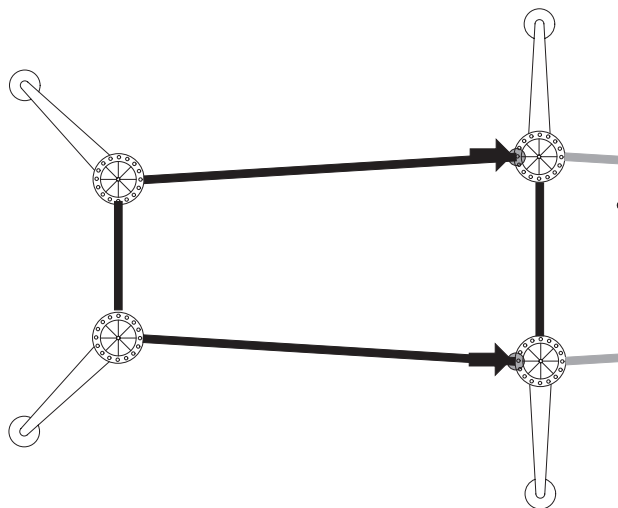
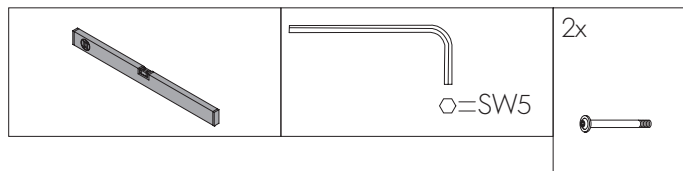
- DE** Leicht anziehen.
- EN** Tighten slightly.
- FR** Serrer légèrement.
- ES** Apriete ligeramente.
- NL** Niet te sterk aandraaien.
- IT** Avvitare leggero.

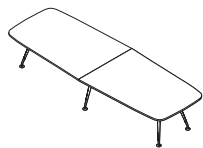

I



1x	6x
	

6x

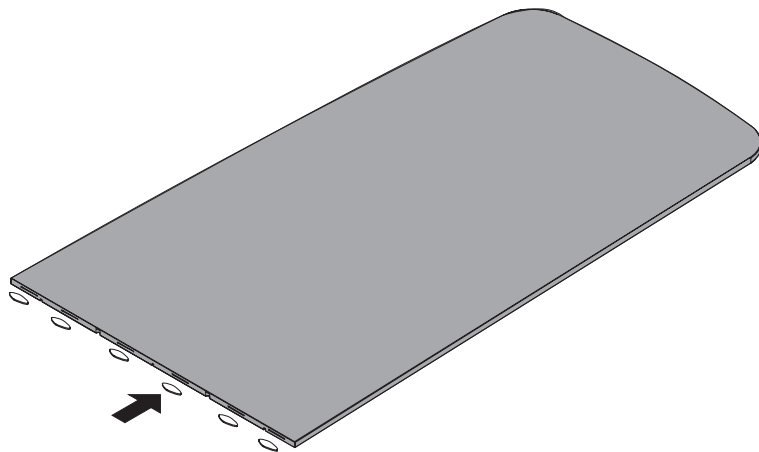
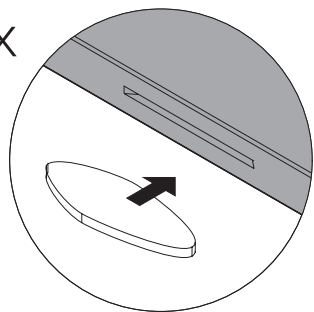

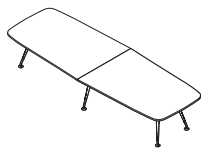
J

- DE** Leicht anziehen.
- EN** Tighten slightly.
- FR** Serrer légèrement.
- ES** Apriete ligeramente.
- NL** Niet te sterk aandraaien.
- IT** Avvitare leggiero.

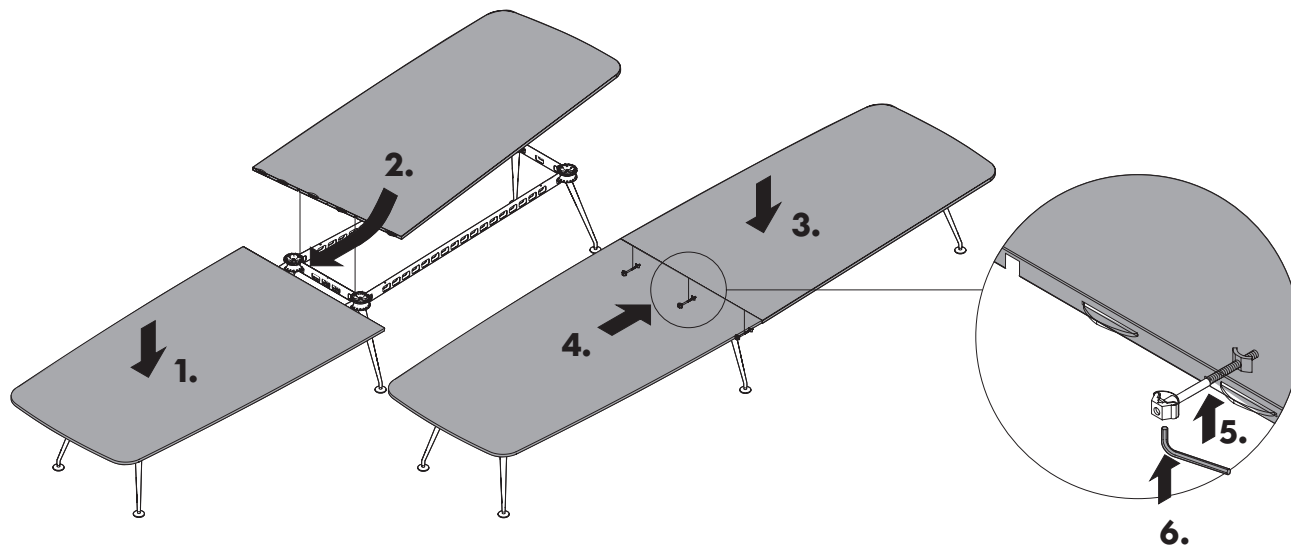
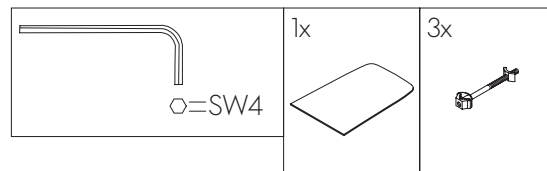

K

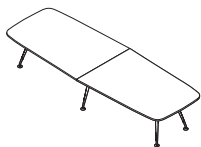

- DE** Leicht anziehen.
- EN** Tighten slightly.
- FR** Serrer légèrement.
- ES** Apriete ligeramente.
- NL** Niet te sterk aandraaien.
- IT** Avvitare leggero.

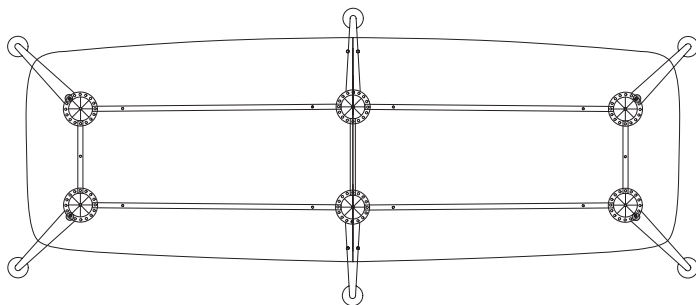
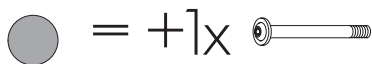
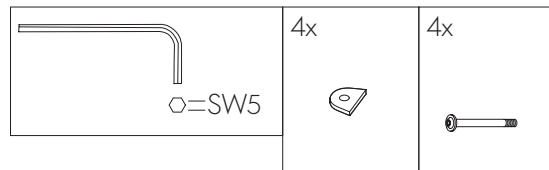

4x

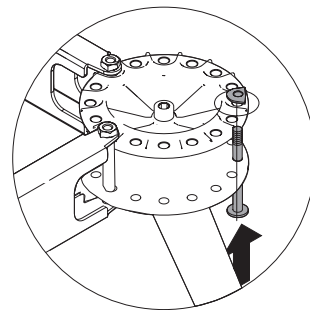

L

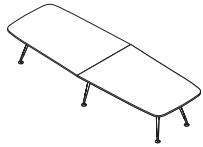



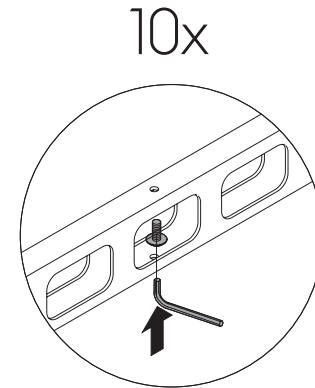
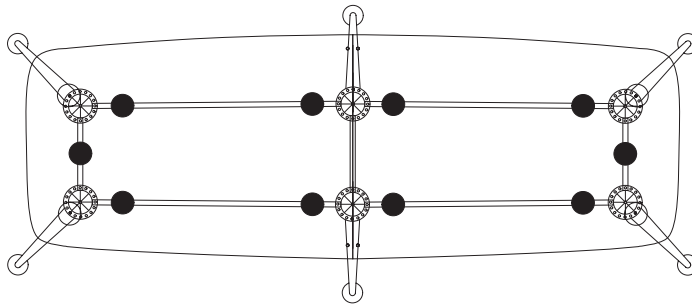
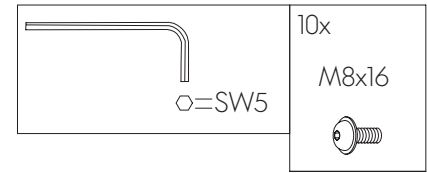

- DE** Alles fest anziehen.
- EN** All thighten fully.
- FR** Tout serrer fortement.
- ES** Todo apriete fijo.
- NL** Alles vast aandraaien.
- IT** Tutto avvitare fermo.

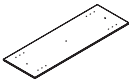

A

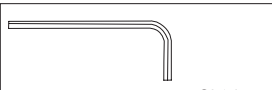

1x 	1x 
2x 	4x 
3x M8x20 	

 ○=SW5

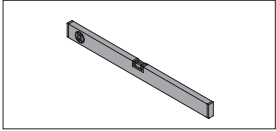

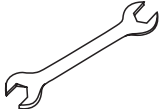



B

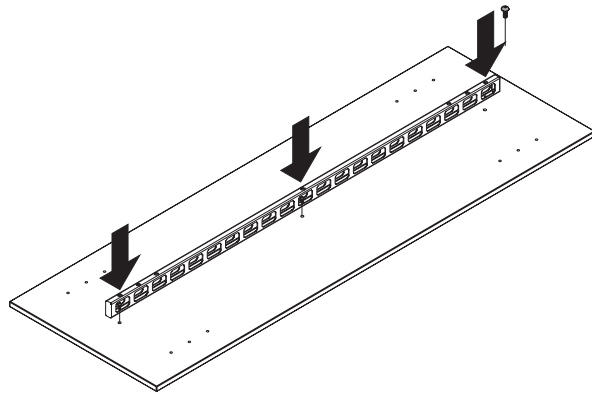
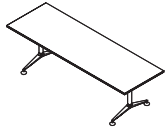

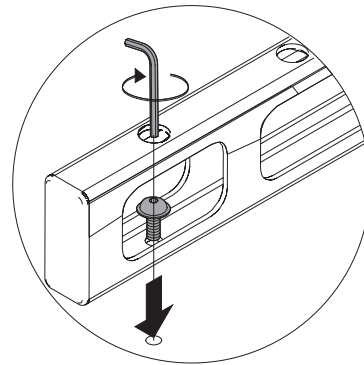

An L-shaped metal bracket with a hole at the end of the shorter leg. <p>○=SW5</p>	1x A rectangular metal plate with a hole at one end.	1x A metal bracket with a hole and a protruding end.	3x M8x20 A screw with a hexagonal head.
---	---	---	---

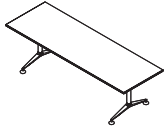

C

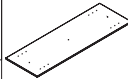

 ○=SW5	1x 	1x 	3x M8x20 
--	---	---	--

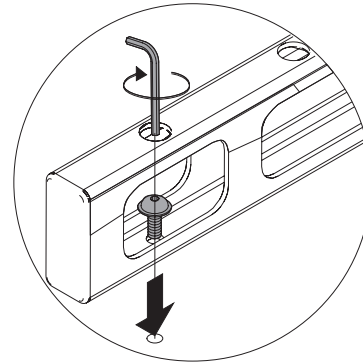
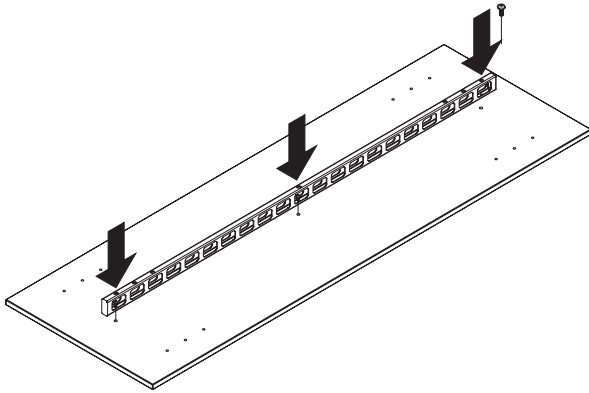

D

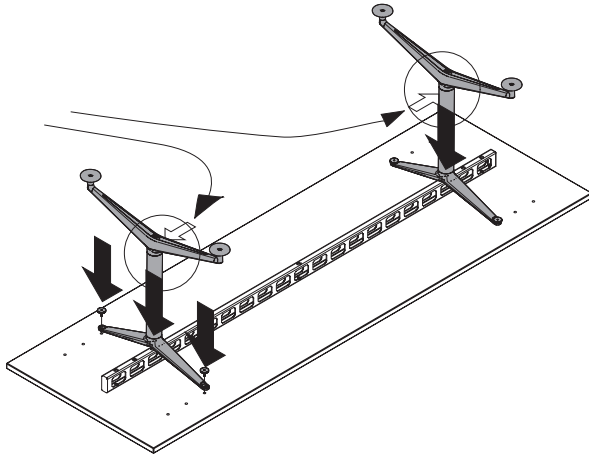
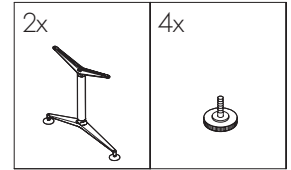
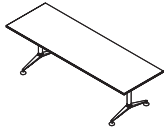

1.

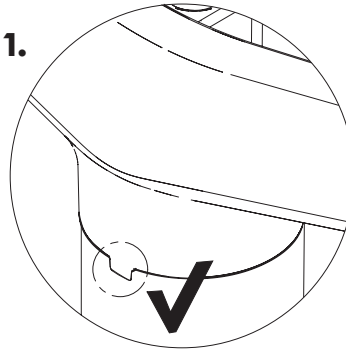

2.

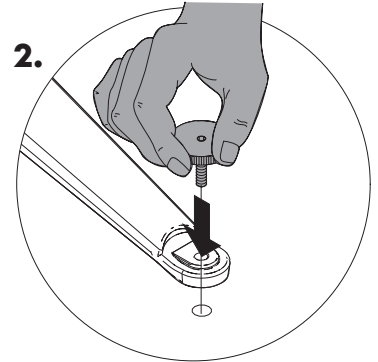

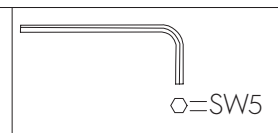
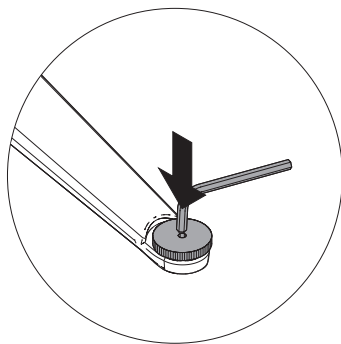
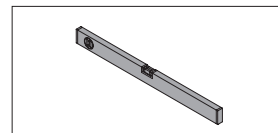
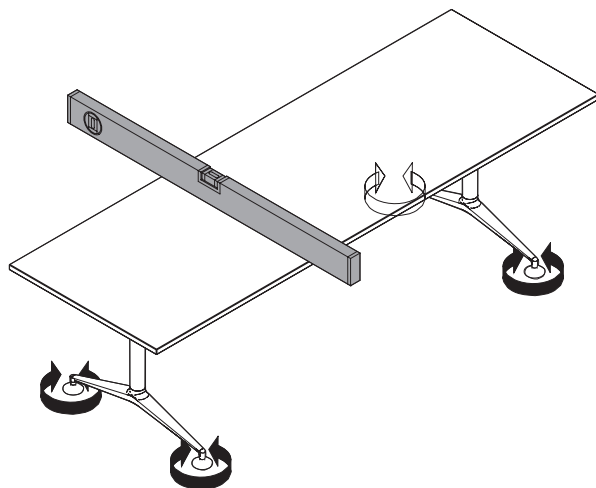
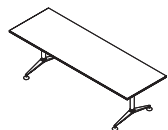
E

- DE** Bei längerfristiger Nutzung der Tische, müssen die Rändelschrauben zusätzlich mittels Inbusschlüssel fest angezogen werden.
- EN** If desks are to be used for longer periods of time. The knurled screws must be tightened fully with an Inbus key.
- FR** Pour en cas d'utilisation prolongée des tables, les vis moletées doivent être aussi serrées fortement avec une clé pour vis à six pans creux.
- ES** Por en caso de un uso prolongado de las mesas, apretar flijo los tornillos moleteados con ayuda de una llave Allen.
- NL** Vanwege de stabiliteit moeten de kartelschroeven bij langduriger gebruik van de tafel met een inbusleutel extra worden faast aangedraaid.
- IT** In caso di utilizzo prolungato del tavolo, i pomelli a vite devono essere aggiuntivamente serrati tramite chiave a brugola.

Notizen/notes/pour note/para nota/Aantekeningen/Appunti/

Notater/Забелешки/Notater/Märkused/Huomautukset/Σημειώσεις/

Piezīmes/Užrašai/Notatki/Observações/Note/Anmärkningar/

Poznámky/Beleške/Notlar/Jegyzetek/Poznámky/Athugasemdir/Bilješke

DE Pflegehinweis

EN

FR

ES

NL

IT

NO Care instructions

BG

⚠️ ACHTUNG! Die Oberflächen verschleiben. Reinigen Sie nur mit einem feuchten Putzlappen und mildem Reinigungsmittel.

⚠️ ATTENTION! Surfaces are subject to wear and tear. Clean with a damp cloth and mild cleaning agent only.

Conseil d'entretien

⚠️ ATTENTION! Les surfaces risquent de s'user. Nettoyez uniquement à l'aide d'un chiffon humide et d'un nettoyeur doux.

Consejos de conservación

⚠️ ¡ATENCIÓN! Las superficies se desgastan. Para limpiar utilice solo una bayeta húmeda y un producto de limpieza suave.

Onderhoudsinstructie

⚠️ OPGELET! De oppervlakken zijn gevoelig voor slijtage. Maak ze alleen schoon met een vochtige doek en mild reinigingsmiddel.

Consigli per la cura

⚠️ ATTENZIONE! Le superfici sono soggette a usura. Per pulirle utilizzare solo un panno umido e un detergente delicato.

Råd om vedlikehold

⚠️ OBS! Overflatene er utsatt for slitasje. De må kun rengjøres med en fuktig klut og et skånsomt rengjøringsmiddel.

Указание за поддръжка

⚠️ ВНИМАНИЕ! Повърхностите се износват. Почиствайте ги само с влажна кърпа и неагресивен почистващ препарат.

Plejeanvisninger

⚠️ OBS! Overfladerne kan blive slidt. Rengør overfladerne med en fugtig rengøringsklud og et mildt rengøringsmiddel.

Hooldusmärkus

⚠️ TÄHELEPANUG! Pinnad võivad kriimustuda. Kasutage puhastamiseks ainult niisket lappi ja pehmetoimelist puhastusvahendit.

Hoito-ohje

⚠️ HUOMIO! Pinnat kuluvat. Puhdistista ne vain kostealla liinalla ja miedolla puhdistusaineella.

Υπόδειξη φροντίδας

⚠️ ΠΡΟΣΟΧΗ! Οι επιφάνειες φθείρονται. Για τον καθαρισμό χρησιμοποιείτε μόνο ένα νωπό πανί και ήπιο καθαριστικό.

Norādījumi par kopšanu

⚠️ UZMANĪBU! Virsmas nodilst. Tīriet tikai ar mīkstu lupatīņu un maigu tīrīšanas līdzekli.

Priežiūros nuoroda

⚠️ DĖMESIO! Paviršiai nusidėvi. Valykite tik drėgnu skudurėliu ir švelnia valymo priemone.

Wskazówka dot. pielęgnacji

⚠️ UWAGA! Powierzchnie ulegają zużyciu. Czyścić tylko wilgotną ścierką i łagodnym środkiem czyszczącym.

Instrução de uso e cuidado

⚠️ ATENÇÃO! As superfícies desgastam-se. Limpe apenas com um pano de limpeza húmido e detergente suave.

RO Indicație de îngrijire

SV **⚠️ ATTENTION!** Suprafețele se uzează.
SK Curățați-le numai cu o cârpă umedă și cu
SL agent de curățare cu acțiune blândă.
TR

HU

CS

IS Skötselánvisning

⚠️ **OBSERVERA!** Ytorna slits.
Rengör endast med fuktig trasa och mild
rengöringsmedel.

Pokyny pre údržbu a starostlivosť

⚠️ **POZOR!** Povrchy podliehajú
opotrebovaniu. Čistenie vykonávajte iba
vlhkou utierkou a jemným čistiacim
prostriedkom.

Napotki za nego

⚠️ **POZOR!** Zgornje površine se lahko
obrabijo. Za čiščenje uporabljajte samo
vlažno krpo in blago sredstvo za čiščenje.

Bakım uyarıları

⚠️ **DİKKAT!** Yüzeyler aşınır. Sadece
nemli bir temizlik bezi ve yumuşak temizlik
maddesiyle temizleyiniz.

Ápolási tanácsok

⚠️ **FIGYELEM!** A felületek kopnak. A
tisztítást nedves törölkendővel és enyhe
tisztítószerezrel végezze.

Pokyny pro údržbu a péči

⚠️ **POZOR!** Povrchy podléhají
opotřebení. Čistěte jen vlhkou utěrkou s
mírným čisticím prostředkem.

Ábending varðandi umhirðu

⚠️ **ATHUGIÐ!** Yfirborðsfletir verða fyrir
sliti. Hreinsið eingöngu með rakri tusku og
mildu hreinsiefni.

Napomene o održavanju

 **POZOR!** Površine su sklone habanju. Čistite ih samo vlažnom krpom za čišćenje i blagim sredstvom za čišćenje.

vitra.